

HCM2030 Hybrid Controller



- 62 configurable I/O
- Programmable
- Designed for 12 VDC and 24 VDC
- RS232
- 3 x CAN
- 3-axis accelerometer
- Built-in gyro (z)

HCM2030 is compact and versatile high power I/O controller with 60 configurable I/O's. 24 of them can be used as current controlled PWM outputs. All of the outputs have at least diagnostics level current measurement.

The unit has a built-in Real Time Clock, which can be used for logging events with a time stamp. In addition to flash there is also battery backed memory for storing fast changing information.

There is also 3-axis accelerometer and gyro as standard.

Technical Information

- 9-32 VDC operating voltage range
(Protected against reverse polarity)
- Maximum simultaneous load 40 A
- -40...+85 °C operating temperature range
- ARM Cortex M7 400 MHz CPU
 - 1 MB SRAM, 2 MB flash memory
- 32 MB external flash memory
- 4 kB battery secured RAM
- IP67 plastic/aluminium housing
- Weight 0.7 kg
- Main dimensions 172 mm x 122 mm x 35 mm
- Three 26 pin AMP Super Seal connector
- 3x CAN Interface 2.0B, ISO 11898
- Real time clock (RTC)
- 3-axis accelerometer
0.1° resolution
- Gyro for Z axis
±250°/sec angular rate sensing

I/O Interface

- Total of 62 configurable I/O
- The I/O interface is protected against short to GND and to supply voltage
- Two reference voltage outputs: 3.3 / 5 / 10 / 12 V (max 150 mA)

I/O interface (continued)

Amount	Configurability	Details
24	Digital input (PNP) Digital output PWM output	Threshold configurable*, max 50 Hz High side driver with current feedback, max. 3 A High side driver with current feedback, max. 3 A
12	Digital input (PNP) Analog input	Low < 1,5 V, High > 3,2 V, max. 50 Hz 12-bit AD conversion 0-10.3V, 69kΩ 0-22mA, 150Ω
6	Digital input (PNP) Pulse input	Threshold configurable*, max. 50 Hz Threshold configurable*, max. 50 kHz Quadrature encoder
8	Digital input (PNP) Digital output PWM output	Threshold configurable*, max. 50 Hz High side driver, max. 3 A High side driver, max. 3 A
4	Digital input (PNP) Pulse input	Threshold configurable*, max. 50 Hz Threshold configurable*, max. 50 kHz Quadrature encoder
4	Digital input (PNP) Digital output	Threshold configurable*, max. 50 Hz High side driver, max. 2 A
2	Digital input (PNP)	Threshold configurable*, max. 50 Hz
4	Digital output Digital input	ON/OFF Low side driver, max. 9 A. Threshold configurable*, max. 50 Hz

*) LOW and HIGH voltage levels are configurable. Possible threshold levels for LOW/HIGH values are 2,7/3,1 V, 4,5/4,9 V and 7,2/7,6V.

Wiring Diagram

TBA

PRELIMINARY

Node ID

Voltage at AI_8	Node ID offset	R (with 12 V ref)
0V	1	Open
0.9V	3	820k
1.9V	5	360k
2.8V	7	220k
3.7V	9	150k
4.7V	11	110k
5.6V	13	82k
6.6V	15	56k
7.5V	17	43k
8.4V	19	30k
9.4V	21	20k
10.3V	23	Closed

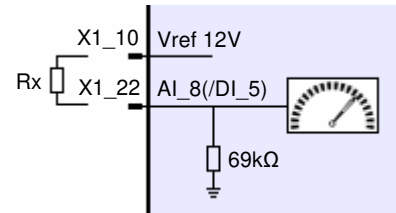

As default the unit's node address is set by voltage level at AI_8.

Node ID = Base Node ID (46) + Node ID offset. See CANopen profile for further details.

Reference voltage 1 (+ref1 / X1_16) provides 5 V during boot and reference voltage 2 (+ref2 / X1_17) provides 12 V.

Quadrature encoders

In HCM2030 there are five separate quadrature encoders. Quadrature input signals (pairs) are compared to each other and with that information module is able to know direction.

Available pins are:

Pair	Pin A	Pin B
1	X2_11	X2_12
2	X2_18	X2_17
3	X1_20	X1_14
4	X1_21	X1_15
5	X1_18	X1_25

Connectors

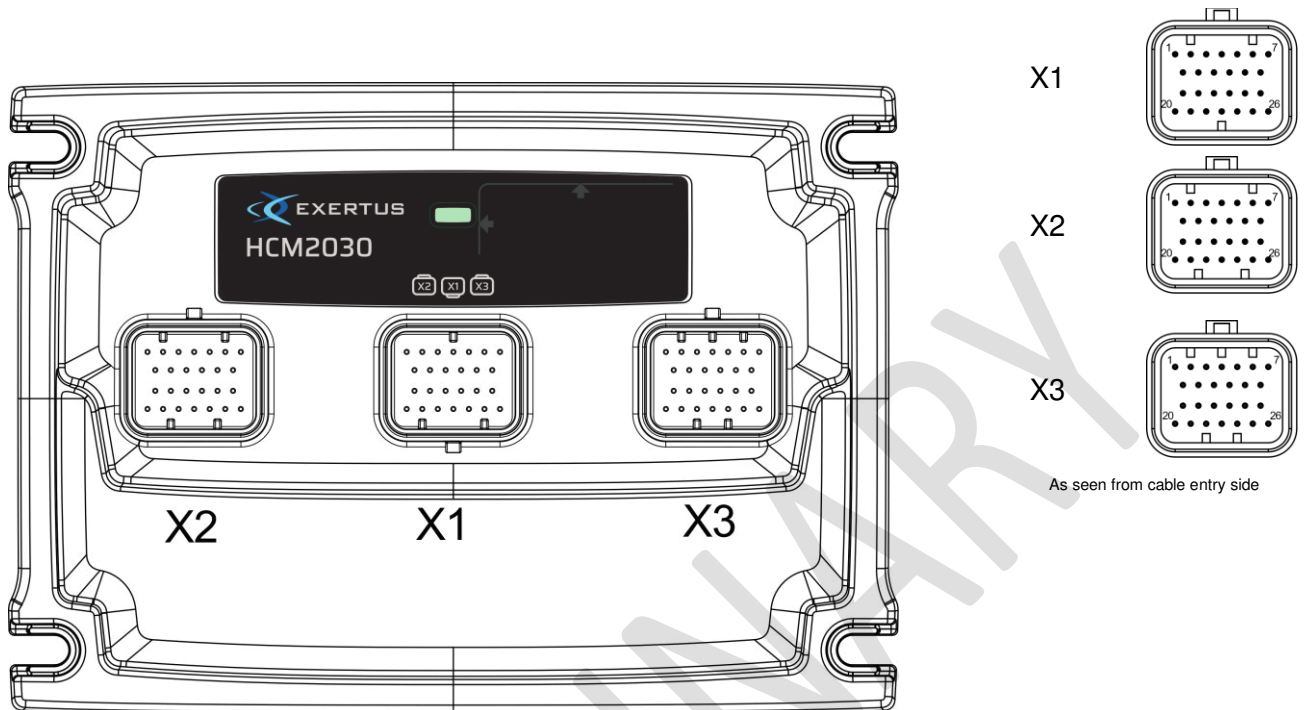

Superseal connectors

Superseal connector needed:

X1: Super Seal Connector Plug Housing	Ø1.6 - 2.2 mm - AMP 3-1437290-7
X2: Super Seal Connector Plug Housing	Ø1.6 - 2.2 mm - AMP 3-1437290-8
X3: Super Seal Connector Plug Housing	Ø1.6 - 2.2 mm - AMP 1473416-1
Receptacle Contact (0.75 – 1.25mm ²)	AMP 3-1447221-3
Filler Plug *)	AMP 4-1437284-3 Deutsch 0413-204-2005

*) Filler plugs must be used on empty cavities to reach waterproofness

Dimensions

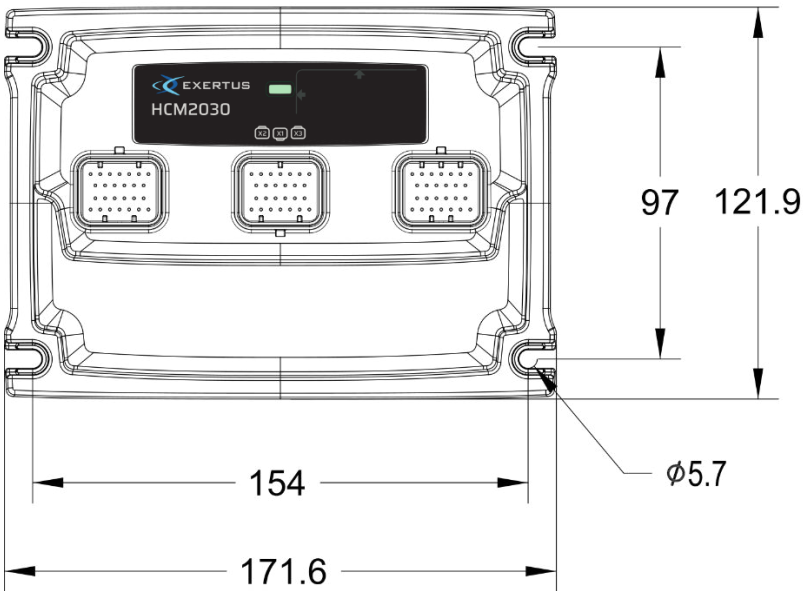
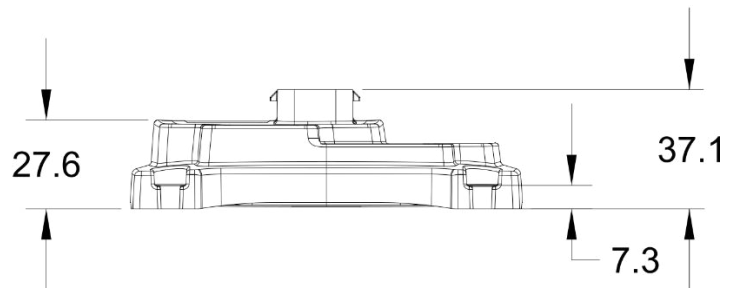
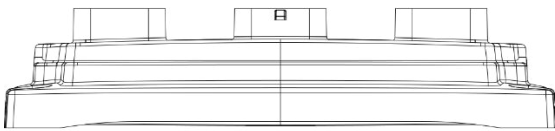
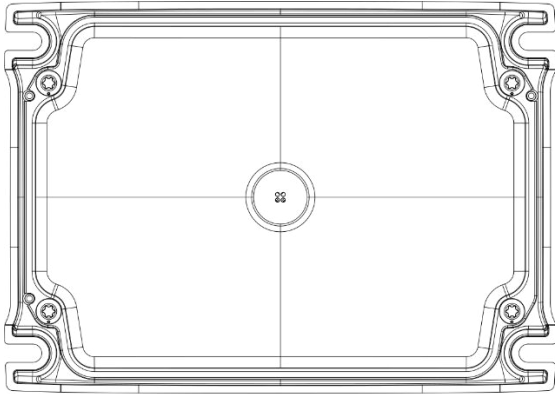

Mounting

HCM2030 is mounted on flat surface with four M5 screws

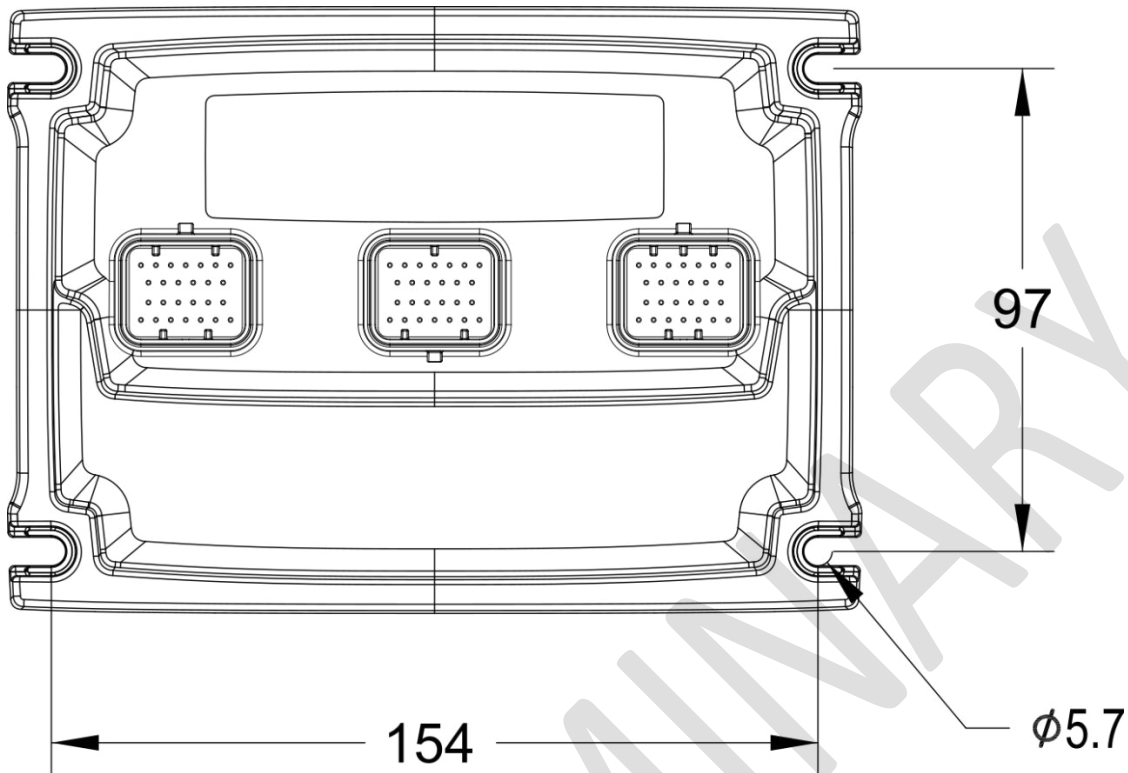

NOTE! Extra care should be paid on grounding of HCM2030. It is recommended to use star lock washer under fastening bolt. Also, extra attention should be paid that lock washer goes through the paint layer.

The preferred mounting position is connectors pointing downwards. If the unit is mounted connectors pointing to the side, then it is vital to leave some loose cable with a downward cue to prevent the ingress of moisture through connector.

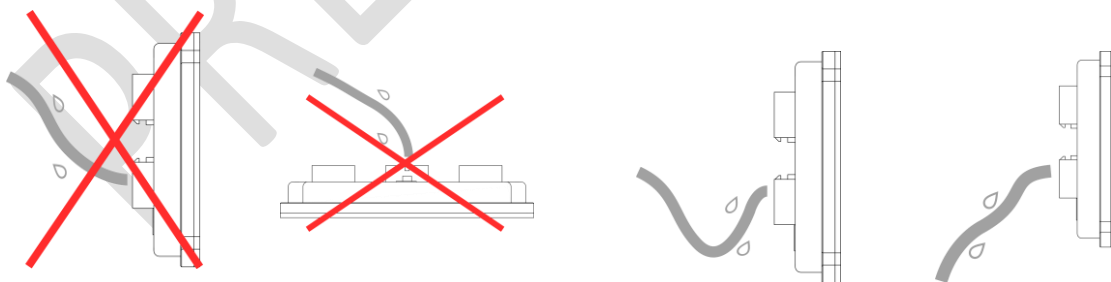

Version	Date	Author	Comments
0.1	10.4.2024	Juho Takalo	Initial version.

PRELIMINARY